

Stressing Anchorage VSL Type ES

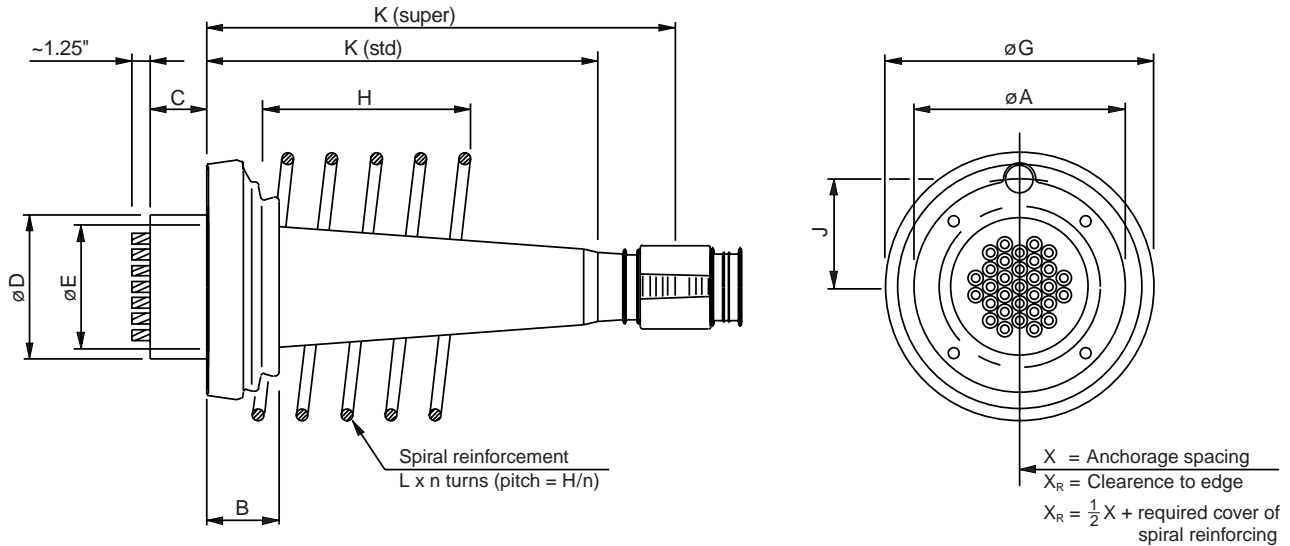

Drawings not to scale

Tendon Unit		Dimensions Inches												
		øA	B	C	øD	øE	øG	H	J	K (std)	K (super)	L	n	X
Strand Type 0.5"	5-12	8.74	2.36	2.38	6.00	4.06	10.50	10.00	4.33	13.00	16.38	#4	5	12.50
	5-19	10.16	3.15	3.00	7.00	5.13	13.75	14.00	4.82	16.93	20.22	#5	7	15.75
	5-31	12.60	3.94	4.00	9.00	6.59	18.00	18.00	5.91	19.69	23.86	#5	9	20.50
	5-43	15.35	4.72	5.20	11.10	8.57	21.75	20.00	7.24	28.75	NA	#5	10	23.75
	5-55	16.54	5.12	5.50	12.00	9.01	24.75	22.50	7.80	27.55	NA	#6	10	26.75
Strand Type 0.6"	6-7	8.74	2.36	2.38	6.00	4.06	10.50	10.00	4.33	13.00	16.38	#4	5	12.50
	6-12	10.16	3.15	3.25	7.00	5.13	13.75	14.00	4.82	16.93	20.22	#5	7	15.75
	6-19	11.81	3.54	3.75	8.25	5.88	17.00	18.00	5.61	19.69	22.13	#5	9	19.00
	6-22	12.60	3.94	4.00	9.00	6.59	18.00	18.00	5.91	19.69	23.86	#5	9	20.50
	6-31	15.35	4.72	5.20	11.10	8.57	21.75	20.00	7.24	28.75	NA	#5	10	23.75
	6-37	16.54	5.12	5.50	12.00	9.01	24.75	22.50	7.80	27.55	NA	#6	10	26.75

Other sizes available on request

Subject to modification

Anchorage spacings are in accordance with test requirements of FIP (Recommendations for Acceptance of Post-Tensioning Systems: March 1992). For proper design and detailing of anchorage zones and related reinforcement, refer to the VSL Publication "Detailing for Post-Tensioning".

Dimensions are valid for:

- Nominal concrete cylinder strength at 28 days: 4,000 psi (28 MPa).
- Maximum prestressing force may be applied when concrete reaches a cylinder strength of 3,500 psi (24 MPa).
- Temporary overstressing to 80% of Guaranteed Ultimate Tensile Strength.
- Yield strength of spiral reinforcement: Grade 60 (400 MPa).

- Additional orthogonal reinforcement may be required in the local anchorage zone as determined by design.
- Spirals may be replaced by suitable orthogonal reinforcement.
- Information for other concrete strengths and conditions are available from your local VSL Representative.

Spiral reinforcement shall be centered on the anchorage assembly and be placed directly behind the bearing plate.