

Bonded, Post-Tensioning at BWI Airport

Concrete system minimizes maintenance of new parking garage

BY JAMES LOPER, DENNIS SANSCHAGRIN, JOHN CRIGLER, AND DON KLINE

When selected by the Maryland Aviation Administration (MAA) to provide design services for the new Baltimore Washington International Airport (BWI) Consolidated Parking Garage, Walker Parking Consultants and Michael Baker Architects opted to use the most advanced techniques and materials possible. This decision was based on the owner's need for maximized durability and minimized maintenance over the structure's projected life cycle. "After considering various other options, such as precast concrete and unbonded post-tensioned concrete," says Bill Reiter of Walker Parking, "we selected bonded, post-tensioned, cast-in-place concrete to minimize joints and promote long-term durability."

While the project had many special features, including fast-track scheduling, preconstruction scale mockups, large area concrete placements, and architectural precast wall panels, the feature that set it apart from other garages was the VSLAB+® post-tensioning system used specifically to minimize life-cycle maintenance costs. This system, and several other unique features of the BWI garage, make it significantly different than typical parking garages.

PROJECT DESCRIPTION

Located in the center of the metropolitan Washington D.C. and Baltimore hub, BWI is one of the fastest growing airports in North America. By the late 1990s, this rapid growth had led to growing concerns about parking availability at the airport. In 2000, the Maryland State Government and the MAA announced a 5-year improvement "VISION" plan to upgrade the airport's functionality. The plan included provisions for a new parking garage located less than 2 mi (3.2 km) from the airport terminal.

The parking facility includes approximately 3.5 million ft² (325,000 m²) of parking space. Over 1 million ft² (93,000 m²) consists of elevated, post-tensioned, cast-in-place concrete. The structure is approximately 1500 ft long x 840 ft wide (460 x 260 m), arranged in 60 x 60 ft (18 x 18 m) bays, and sits on spread footings that are up to

3.5 ft thick x 16 ft wide x 16 ft long (1 x 5 x 5 m). The slab-on-ground is 6.5 in. thick (165 mm), is reinforced with welded-wire fabric, and has contraction joints at 20 ft (6 m) on center each way. The elevated deck consists of a post-tensioned concrete beam and slab system (Fig. 1). Slabs (5.5 in. thick [140 mm]) span 20 ft (6 m) between beams that span 60 ft (18 m) to girders or columns. Concrete compression strength (cylinder) at 28 days is 5000 psi (35 MPa).

POST-TENSIONING CONCEPTS AND OPTIONS

Two options for post-tensioning parking garages are unbonded and bonded systems. The characteristic feature of an unbonded tendon is that it does not form a bond along its length in the concrete. Unbonded tendons are comprised of single strands (monostrands) covered with a grease coating and enclosed in high-density plastic extruded sheathing. Primarily, the end anchors transfer the force in the stressed tendon to the concrete.

A bonded tendon is usually comprised of multiple post-tensioning strands and, by design, forms a continuous bond along its length with the surrounding concrete slab, beam, or girder. A cementitious grout that surrounds the strands bonds them to the concrete. The grout acts with the duct that is encased in the concrete member to complete the bond path between the post-tensioning strands and the concrete member. Flat, corrugated, polypropylene (PP) ducts that house two to five strands are used in thinner members such as slabs, whereas larger, round ducts (PP or galvanized metal) are used in beams and girders.

WHY USE BONDED POST-TENSIONING IN PARKING GARAGES?

Bonded systems are becoming more popular with long-term owners such as airports, hospitals, government agencies, and universities. Approximately 3.5 million ft² (325,000 m²) of bonded post-tensioning



Fig. 1: The elevated deck of the new parking structure at BWI airport is constructed as a post-tensioned concrete beam and slab system

has been installed in the U.S. in building slabs since 1995. This interest is based on the life-cycle economies associated with bonded systems compared to unbonded systems.

Bonded systems offer a significant design advantage that leads to life-cycle savings. The key design feature is that the hardened grout locks the movement of the post-tensioning strands to that of the surrounding concrete. Hence, the force in a bonded strand is a function of the deformation of the surrounding concrete. This is the well-known concept of strain compatibility and internal equilibrium used in reinforced concrete design.

Another design advantage of bonded post-tensioning is the inherent capacity to provide resistance to progressive collapse. This may be especially important in the event of localized blast loading. Like conventional steel reinforcement, a bonded post-tensioning tendon is capable of developing its force at a relatively near distance along its length. In the event that an anchorage fails or a strand is severed, the

loss of tendon force would be localized. The remainder of the tendon would retain its force at the development length away from the failure point and would remain functional. This functionality may be used in the design phase when planning for alternative load paths.

Bonded systems also offer several practical benefits compared to unbonded systems. The most important benefit is reduction of steel reinforcing bars, particularly at the top of slabs. This is especially important because most parking garage maintenance costs are due to repairs associated with spalled concrete and corroded reinforcement. Another benefit is complete encapsulation: strands are fully protected by cementitious grout, the duct, and the surrounding concrete. Bonded systems also offer more flexibility regarding structural modifications such as openings for stairwells, utility access, and future expansion.

SPECIAL FEATURES OF THIS PROJECT

The signature feature of this project is the bonded post-tensioning system designed to minimize long-term maintenance costs. The VSLAB+ system provides total encapsulation of the strands using a high-density plastic duct with watertight mechanical duct-to-anchorage couplers (Fig. 2 and 3). Permanent end-caps (for both beam and slab tendons) are included to completely seal the anchorages. High-performance grout pumped through the tendons provides an additional layer of protection.

Close attention to detailing, field coordination, and quality control played an especially important role on this project due to an aggressive schedule. The post-tensioning contractor (VSL) was responsible for material supply, detailing, installation, and quality control of the VSLAB+ system. Many of the key decisions made during the detailing phase were a collaborative effort between the design engineer (Walker Parking), the general contractor (Facchina Construction), the reinforcing bar installation contractor (Cortes Brothers) and the post-tensioning contractor.

Early in the detailing process, the challenge associated with coordinating intersecting post-tensioning anchors at corner columns was identified. Computerized drawings of the original layout indicated that the anchors would interfere with each other. To solve this challenge, the post-tensioning contractor and the general contractor constructed a full-scale corner connection mockup to verify that post-tensioning anchorages and associated steel reinforcing bars would fit within the space available. Working closely with the design engineers, the construction team made slight adjustments to ensure adequate fit-up and constructibility while maintaining the structural intent.

Special Products & Practice Spotlight

The post-tensioning contractor took special care to grout the tendons after they completed stressing. “Based on the project specifications and industry guidelines,”¹ explains VSL project engineer Shih-Wei “Jerry” Peng, “we drafted a grouting procedure for our field personnel that detailed the grout materials, equipment, grouting procedure, testing, and documentation requirements.” This written procedure was a tool used throughout the project for quality control and communication. A high-performance, low-bleed grout with special admixtures was used to meet the Post-Tensioning Institute’s (PTI) requirements¹ for grouting post-tensioned tendons. The grout mixture design called for one 30 lb bag of premixed admixture to every three 94 lb bags of cement, and a water-cementitious material ratio (w/cm) of 0.32.

Grouting equipment included a gravity system to feed grout into the pump inlet from a hopper. The hopper was kept partially full of grout at all times during the pumping operation to prevent air from being drawn into the tendon duct. The post-tensioning contractor used a special high-shear mixer (Fig. 4a) to produce grout free of lumps and undispersed cement. While the equipment has a grouting capacity of approximately 30 gpm (110 L/min) at 200 psi (1400 kPa), normal operating pressure was approximately 75 psi (520 kPa). Grout vents with mechanical shut-off valves were strategically placed along the length of the draped tendons in the beams and girders to release air. The post-tensioning contractor added vents at intermediate locations (in addition to drape high points and low points) to ensure full encapsulation of the strands.

Table 1^{1,2} shows the various field and laboratory quality control tests (Fig. 4b) that were performed regularly on the grout: the Schupack Pressure Bleed Test is useful for estimating the percentage of bleed water; the Mud Balance Test provides an indication of the grout density and may be used to verify the w/cm ; and the Flow Cone Test involves measuring efflux time of a grout sample through a standard cone and provides an indication of pumpability and fluidity. Several techniques were employed to reduce

the temperature of the grout components. Shading of the dry materials, adding ice to the mixing water, and early morning start times were effective.



Fig. 2: The VSLAB+ system totally encapsulates the post-tensioning strands using a high-density plastic duct

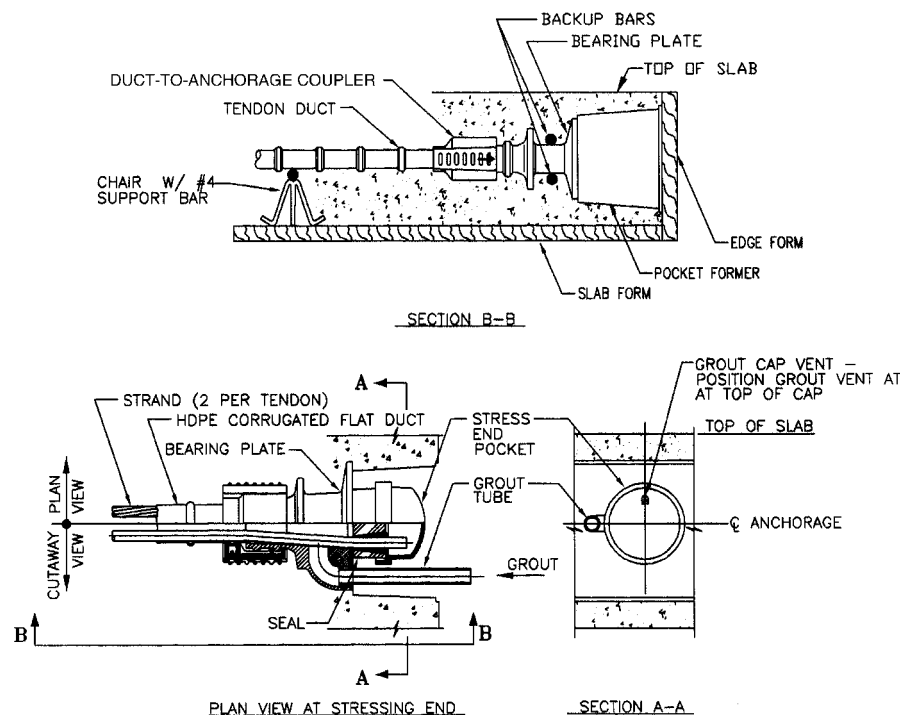

Fig. 3: Schematic detail of the tendon anchorage assembly in the slabs at the BWI airport

Special Products & Practice Spotlight

The large quantity of strand involved (over 3 million linear ft [900 km]) and the aggressive placement schedule required strict control of stressing and grouting operations. Workers partially stressed the slab tendons (Fig. 2, 3, and 5) (10 kips/strand [45 kN/strand]) on the day after concrete placement to help control shrinkage cracking and completely stressed them once concrete test cylinders, cured under job site conditions, reached a compression strength of 3200 psi (22 MPa). The beam and girder tendons did not require partial stressing. These tendons were fully post-tensioned when the concrete compressive strength reached 3200 psi (22 MPa).



Fig. 4: A high-shear mixer was used to produce lump-free grout and undispersed cement for the post-tensioning strands (a); here, a technician tests the grout using various quality control tests (b)

Stressing records and load-cell testing were used to ensure the initial force after friction loss in each tendon was within $\pm 7\%$ of the calculated value. VSL project engineer Lee Siridumrongphun explained: “Based on ACI 318 and other technical literature, we estimated short-term and long-term losses. Realistic estimates are especially important at service loading because overestimation of losses can be almost as detrimental as underestimation because overestimation can result in excessive camber and horizontal movement. Load cell monitoring helped us calibrate and further refine the friction calculations coefficients.”^{3,4} The friction (μ) and wobble (K) coefficients used on this project were 0.15 and 0.0015, respectively. The post-tensioning contractor used a special two-strand hydraulic ram to stress the slab tendons (Fig. 5). This allowed both strands to be stressed simultaneously, which reduced friction losses by 15 to 20%. Table 2 shows typical design jacking forces. Figure 6 shows multistrand anchorage details.

Based on design considerations discussed previously, most of the top steel reinforcing bars in the slab were eliminated due to the use of bonded post-tensioning. It is interesting to note that the slab at the first interior beam support required top reinforcement due to larger bending moments at the end-span. There were additional savings due to the elimination of a corrosion-inhibiting admixture.

The VSLAB+ post-tensioning system worked particularly well with garage functionality requirements. While standard commercial parking garages typically have 20- to 30-ft-wide (6 to 9 m) x 54-ft-long (17 m) bays, the column grid spacing for this project was 60 x 60 ft (18 x 18 m) to allow more flexibility. According to Walker Parking project manager Jason Gross, “The larger bay spacing was important

because each rental car company wanted as much clear space at the bottom level as possible to allow for staging and multi-directional traffic.” Also, the floor-to-floor height was 19 ft (6 m) to provide customers with the feel of an open structure.

Another interesting feature of this project was the concrete placement. The original design layout called for 93 concrete placements at approximately 10,000 ft² (930 m²) each. Based on past experience and careful preplanning, the team opted to increase the placement size to 33,000 ft² (3100 m²). “Each placement required approximately 1100 yd³ (840 m³) of concrete,” explained Paul Barry of Facchina Construction, “and most of the concreting was scheduled for early morning

TABLE 1:
TYPICAL TENDON GROUTING TESTS AND RESULTS (SEE REFERENCE 1 FOR MORE INFORMATION ON TEST PROCEDURES)

Test	Frequency	Typical results	Comments
Schupack pressure bleed test ²	Once daily	2.5% or 5 mL per 200 mL	% bleed = bleed (mL)/200 mL
Mud balance test	Twice daily, perform at inlet and outlet.	2.00 to 2.02 g/mL	Sample weight (g) Sample volume (mL)
Grout compressive strength test (cubes)	3 at 7 days 3 at 28 days	4000 to 4500 psi (28 to 31 MPa) 5500 to 6000 psi (38 to 41 MPa)	—
Flow cone test	Every 2 h: one test at mixer, one test at outlet.	13 to 26 s (depending on ambient conditions)	Time required for sample grout to flow through standard flow cone.

Special Products & Practice Spotlight

hours to ensure steady concrete delivery and to take advantage of cooler temperatures during the summer-time.” This change provided multiple benefits that improved the schedule. The number of concrete placements was reduced from 93 to 36, eliminating



Fig. 5: The post-tensioning contractor used a special two-strand hydraulic ram to stress the tendons in the slab at the new BWI airport parking structure

associated bulkheads and joints, and streamlining the post-tension stressing and grouting operations.

RESULTS

Based on a cooperative effort fostered by the owner, the project team is on track to deliver for a November

TABLE 2:
TYPICAL POST-TENSION TENDON SIZES AND FORCES

Member type	Tendon description*	Tendon jacking force [†]	
		kips	kN
Beams	Up to 31 strands	1023	4550
Girders	Up to 50 strands	1650	7339
Slabs:			
Span direction	2 strand tendons at 2 ft-5 in. (0.74 m) o/c	66	294
Transverse direction	(3) 2-strand tendons per 20 ft (6.1 m) bay width	66	294

* Tendon lengths ranged from 180 to 240 ft long (55 to 75 m).

† Tendon jacking force is based on 33 kips (150 kN) per strand.

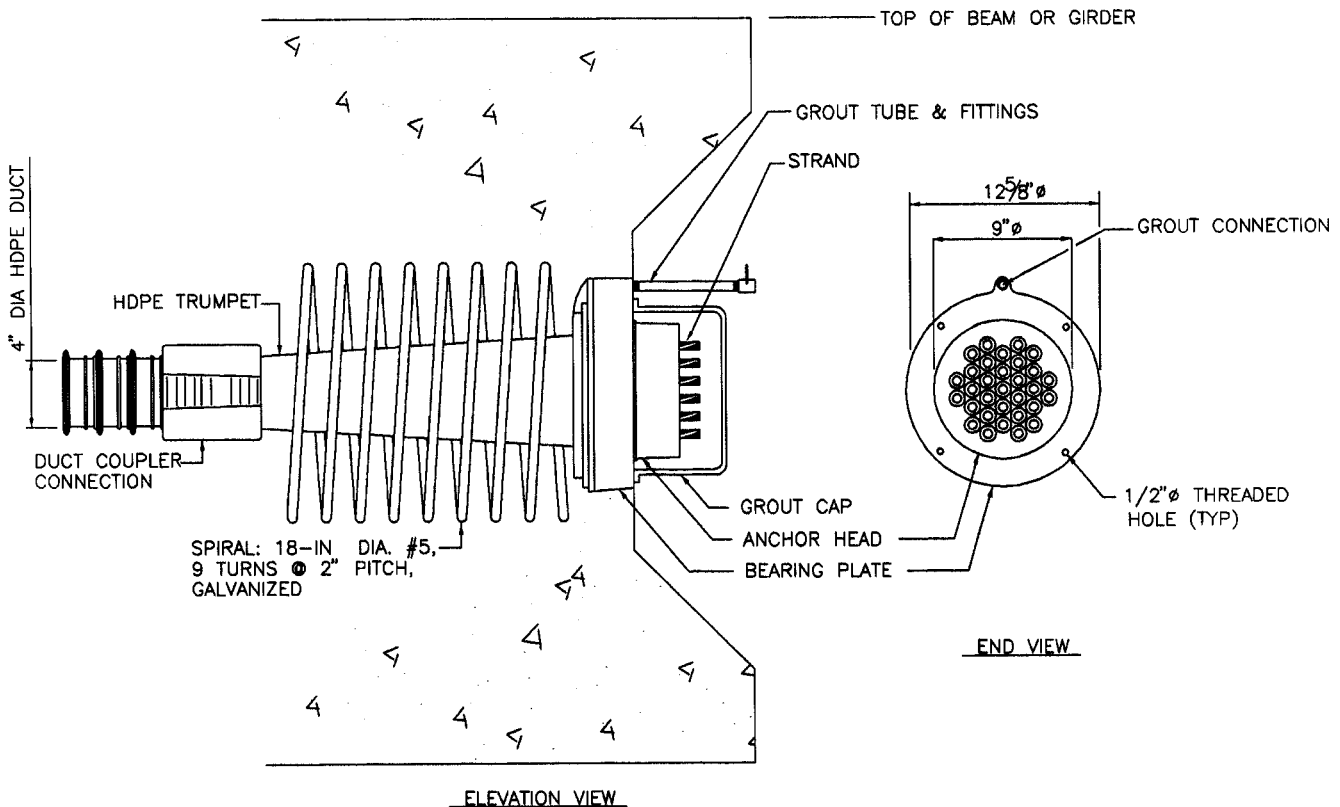

Fig. 6: Schematic detail of the tendon anchorage assembly in the beams at the BWI Airport

Special Products & Practice Spotlight

2003 grand opening of the garage. Once complete, the facility will offer customers one-stop rental car shopping and will free up more than 1000 prime parking spaces in the terminal parking garage. More than 73,000 yd³ (56,000 m³) of cast-in-place concrete will have been used to construct the foundations and superstructure during the 2-year fast-track construction cycle. Careful preplanning, preconstruction mockups, and collaborative input by all project participants were the keys to success on this project.

THE FUTURE

Although the BWI Consolidated Parking Garage is unique in some ways, many of the techniques and materials used are becoming more commonplace for building projects where long-term owners are seeking to minimize life-cycle costs. Grouting certification programs offered by the American Segmental Bridge Institute (ASBI) have been helpful as more concrete framing contractors and reinforcement installers are becoming familiar with bonded post-tensioning systems. Furthermore, owners, engineers, and contractors are recognizing the value of team-oriented participation and safety programs from the beginning of the project.

References

1. *Guide Specification for Grouting of Post-Tension Structures*, Post-Tensioning Institute, Phoenix, AZ, First Edition, Feb. 2001., 69 pp.
2. Schupack, M., "Admixture for Controlling Bleed in Cement Grout Used in Post-Tensioning," *Precast/Prestressed Concrete Institute Journal*, Nov.-Dec. 1974, pp. 1-10.
3. ACI Committee 318, "Building Code Requirements for Structural Concrete (ACI 318-02) and Commentary (318R-02)," American Concrete Institute, Farmington Hills, MI, 443 pp.
4. Zia, P.; Preston, H.; Scott, N.; and Workman, E., "Estimating Prestress Losses," *Concrete International*, V. 1, No. 6, June 1979, pp. 32-38.

PROJECT PARTICIPANTS:

Owner: Maryland Aviation Administration
Program Manager: Parsons Transportation
Architectural Design: Michael Baker Jr., Inc.
Structural Engineer: Walker Parking Consultants
Inspection Services: Parsons Brinkerhoff Quade & Douglas, Inc.
General Contractor: Facchina Construction Co., Inc.
Post-Tensioning Contractor: VSL
Reinforcement Placement Contractor: Cortes Brothers Rebar, Inc.
Ready-mix Concrete Supplier: D&G Brice Ready-Mix

Selected for reader interest by the editors.

—VStructural LLC
CIRCLE 57



James Loper works in the business development group with VSL in Springfield, VA. He earned his bachelor's and master's degrees in civil engineering from Texas A&M University and his MBA from Georgia State University. He is a registered engineer with more than 15 years of experience in design and construction of industrial, military, and commercial

projects. Loper is actively involved in ACI Committees 360, Design of Slabs on Ground; 364, Rehabilitation; and Joint ACI-ASCE Committee 423, Prestressed Concrete.



Dennis Sanschagrln is a VSL project manager in Springfield, VA, with 11 years of experience in the construction, repair, and retrofit of post-tensioned structures. He earned his bachelor's degree in civil engineering from the University of Maryland and is currently working towards an MBA at George Mason University.



John Crigler is a vice president with VSL in Hanover, MD. He is a registered engineer with more than 23 years of experience in the design and implementation of a wide variety of post-tensioning systems and equipment for buildings and bridges. He earned a bachelor's degree in civil engineering from Virginia Tech. He is actively involved in PTI and ASBI committee activities.



Don Kline, VSL's Branch Manager in Springfield, VA, has 12 years of experience in the design/management of post-tensioned concrete applications. He earned his bachelor's degree in aerospace engineering from the University of Virginia and his master's degree in structural engineering from Virginia Tech. Kline is active in various PTI committees and is a member of Joint ACI-ASCE Committee 423, Prestressed Concrete.